



Check Rite®

Rite Sized Check Valves

ASME Class 125 – 2500
1" (25mm) – 60" (1500mm)



A
Bray
High
Performance
Company



Ritepro Corporation
A Subsidiary of Bray International, Inc.

Ritepro Corporation, headquartered in Quebec, Canada and founded in 1963, designs and manufactures exceptional Check Rite check valves, cam and groove quick couplings, and fluid handling loading and unloading equipment. For over 40 years, Ritepro has earned a reputation for reliability. This reputation is based on our highest quality manufacturing standards, premium components and thorough control procedures. With a worldwide sales and distribution network, we offer our customers full support wherever the project location.

Our engineers specialize in innovative, individual solutions to industry needs and will assist you with your project requirements. Our knowledgeable sales and support staff are committed to outstanding service and, above all, customer satisfaction. We look forward to recommending a practical and economical solution to your fluid control applications.

Check Rite Valves continue to be the premier wafer combination swing check valve. Designed in 1970, their performance remains unsurpassed. The line offers a wide range of valves and accessories, all fully stocked and readily available. Their successful, long term use in applications worldwide has made the Check Rite the industry standard for economy, durability and reliability.

Check Rite®

State of the Art Check Valves, Check Rite is Rite Sized.

Ritepro's Check Rite wafer combination swing check valves are flow-activated and *Rite Sized*. Check Rite inlet ports and disc have been shape optimized to achieve a fully open position at low flow rates (3 ft/s on average). Therefore, the Check Rite operates exceptionally well in the flow rates typically found in pipelines containing control valves and lines with varying media flows.

Compare the Check Rite to typical full-sized swing check valves. Due in part to their oversized, heavier discs, these valves only fully open at an average flow rate of 11 ft/s. When activated at a lower flow rate, these valves lose true controllability and do not fully open. A partially open disc creates an obstruction that produces a higher pressure drop and fluttering of the valve disc – disturbing the flow and increasing the chance of water hammer.

Check Rite is *Rite Sized* to eliminate these problems. It has been engineered to accelerate line media through the valve and achieve a virtually unobstructed full opening in low pressure. *Rite Sized*, combined with the limited movement of internal parts during operation, reduces wear – enhancing the long service life of a Check Rite valve.



SIZE RANGE
1" (25mm) – 60" (1500mm)
ASME CLASS
125 - 2500
API, DIN, BS, JIS
Classes Available



ZERO LEAKAGE Check Rite valves, either resilient or metal seated, offer zero leakage in all pressure classifications. Each valve is hydrostatically tested at the factory and shipped with a certificate of compliance to MSS SP61. Ritepro has achieved zero leakage metal-to-metal sealing by a proven, engineered design backed by high quality manufacturing craftsmanship. As the disc closes toward the seat, the increased velocity of the line media and the unique shape of our seat remove all particles from the sealing surfaces – ensuring zero leakage.

LOW PRESSURE DROPS The low pressure drop of the Check Rite valve was achieved by Ritepro's many years of research and development in combination with universities and federal research agencies. Several theses and papers were published including *Minimizing the pressure loss of wafer type swing check valve ASME 79/MA-NE-5*. These results – primarily the optimum valve diameter and elliptical inlet shape – have been incorporated into the Check Rite design. Like a venturi, the aerodynamic shape accelerates the line media through the valve with the lowest possible pressure drop. Pressure drops at the full open position are between 0.5 to 0.7 psi for all size valves. Additionally, the disc shape and mass have been optimized to use the pipeline media flow as a lifting force on the disc, thus allowing a full open valve position in low line velocity.

HIGH FLOW CAPACITY Check Rite's valve inlet elliptical shape and optimum diameter, plus its virtually unobstructed opening combine to produce a substantially higher flow capacity (C_v) than other wafer combination swing check valves.

REDUCED WATER HAMMER An additional focus of Ritepro's R&D program was linked to Water Hammer Prediction. Findings were applied in the design of the valve to largely reduce or eliminate water hammer by closing the valve at the right moment (before reverse flow occurs). The Check Rite uses gravity, assisted by an internal spring, to pull the disc toward the closed position on decelerating line media flow. Ritepro has developed proprietary predictive software to select the best solution for your specific application.

The elliptical shape of the inlet port accelerates the line media through the valve.

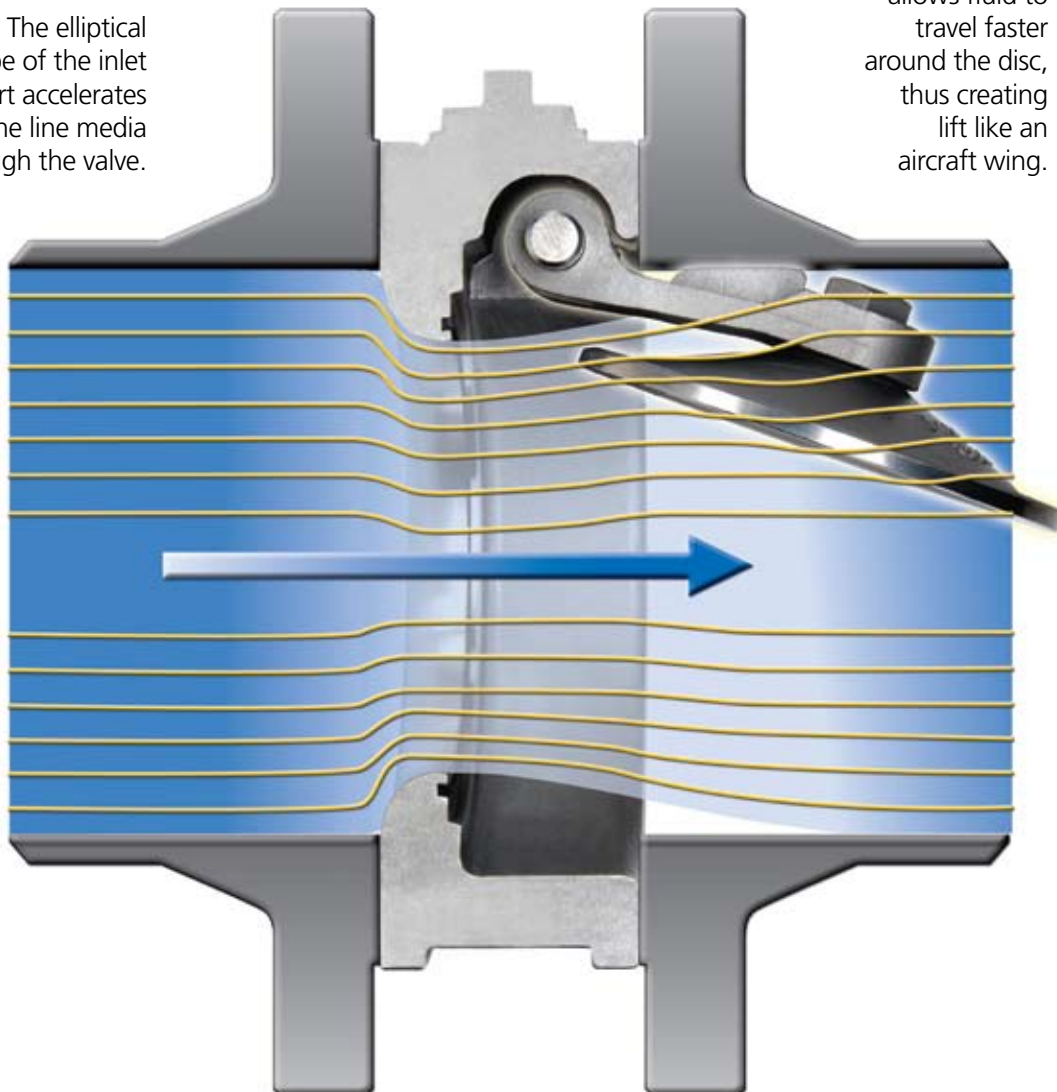

The disc's angle and shape allows fluid to travel faster around the disc, thus creating lift like an aircraft wing.

CHECK RITE SEATS Zero leakage shut off, even at 0 psi, is achieved through lapped metal seating surfaces. The seat and the disc edges are precisely machined then hand polished for a perfect fit. The disc hinge provides an even force at the disc to seat contact point, ensuring a uniform seal. Controlled tolerances maintain the proper disc to seat alignment. The spring assisted closure tension holds the disc in place when line pressure is removed.

RESILIENT SEATS A dynamic, O-ring seat is contained in a specially designed body groove. As line pressure is applied, the valve disc uniformly compresses the seat into the groove ensuring a zero leakage seal. The seat is easily replaced, simplifying maintenance.

METAL-TO-METAL SEATS Integral metal seats feature an engineered and precision machined angle that minimizes the metal-to-metal contact point between the disc and seat for a perfect seal. Pressure is applied evenly over the disc, eliminating galling and reducing wear.

METAL SEAT INSERT Carbon steel and ductile iron bodies have a stainless steel seat inserted into the body seal area, offering the same precision design as the integral metal-to-metal seat. These bodies are also available with a Resilient Seat Insert.

INHERENTLY FIRE SAFE All Check Rite valves are inherently fire safe due to the valve design, materials and construction. In the event of a pipeline fire, both resilient seated and metal seated valves provide metal-to-metal contact between the seat and disc and surpass all leak test standards.

Pressure Drop with Water

| Valve Size | Cv | Min Flow To Fully Open Valve | | Pressure Drop At 10Ft/sec |
|------------|--------|------------------------------|---------|---------------------------|
| | | GPM | Ft/sec. | PSI |
| 1 / 25 | 30 | 28 | 10.4 | 0.78 |
| 1.5 / 40 | 38 | 68 | 10.7 | 2.1 |
| 2 / 50 | 84 | 46 | 4.4 | 1.7 |
| 2.5 / 65 | 137 | 76 | 5.1 | 1.4 |
| 3 / 75 | 221 | 197 | 8.5 | 1.1 |
| 4 / 100 | 373 | 157 | 4 | 1.4 |
| 5 / 125 | 679 | 352 | 5.6 | 1.1 |
| 6 / 150 | 931 | 367 | 4.1 | 1.5 |
| 8 / 200 | 1,440 | 428 | 2.7 | 1.6 |
| 10 / 250 | 2,623 | 837 | 3.4 | 1.1 |
| 12 / 300 | 3,531 | 1,229 | 3.5 | 1.2 |
| 14 / 350 | 3,226 | 1,180 | 2.7 | 2 |
| 16 / 400 | 3,911 | 1,447 | 2.5 | 2.6 |
| 18 / 450 | 5,799 | 3,376 | 4.8 | 1.7 |
| 20 / 500 | 7,769 | 6,500 | 6.3 | 1.5 |
| 24 / 600 | 10,105 | 8,321 | 5.9 | 1.6 |
| 30 / 750 | 18,041 | 10,303 | 5.1 | 0.9 |
| 36 / 900 | 25,675 | 15,850 | 5.2 | 2 |
| 42 / 1050 | 47,914 | 31,304 | 7.5 | 2.7 |
| 48 / 1200 | 44,983 | 33,095 | 5.9 | 1.6 |
| 54 / 1350 | 63,000 | 45,000 | 6 | .9 |
| 60 / 1500 | 70,500 | 62,800 | 6.2 | 1.1 |

Notice the full open stable minimum velocity and the efficiency calculated at a normal velocity of 10 f/sec.

Resilient Seat



Metal-To-Metal Seat



Metal Seat Insert



The convex profile of the disc reacts to line flow like an airfoil. The velocity above the disc is higher than the velocity below, thus effectively creating lift.

PUMPING COST SAVINGS Pumping costs have been often overlooked but are now gaining in importance due to the increasing cost of energy. With Check Rite's long service life, its cost is actually insignificant to the end user

compared to the energy lost pumping the fluid through the valve. Below is a comparison between different valve styles, assuming all valves are 100% open.

Yearly Energy Costs At 10 F/S - \$0.10/kWh

| VALVE SIZE / INCHES | 2 | 2.5 | 3 | 4 | 5 | 6 | 8 | 10 | 12 |
|------------------------|-------|-------|-------|-------|---------|---------|---------|---------|---------|
| Check Rite | \$42 | \$66 | \$99 | \$174 | \$250 | \$254 | \$635 | \$872 | \$1,113 |
| Tilting Disc | \$50 | \$66 | \$102 | \$161 | \$250 | \$272 | \$425 | \$606 | \$739 |
| Center Guided "Silent" | \$115 | \$214 | \$339 | \$608 | \$1,002 | \$1,409 | \$2,541 | \$4,006 | \$3,447 |
| Full Size Swing Check | \$57 | \$66 | \$99 | \$191 | \$250 | \$415 | \$680 | \$1,002 | \$1,347 |
| Dual Door | \$218 | \$209 | \$314 | \$441 | \$491 | \$707 | \$979 | \$1,118 | \$1,282 |

HORIZONTAL / VERTICAL INSTALLATION

Unlike most conventional check valves, Check Rite wafer combination swing check valves are ideal for both horizontal and vertical pipeline installation – requiring only a single line for operation. This greatly increases pipeline layout flexibility

and significantly reduces costs. In vertical installations, typical swing check valves must have an offset pipe section installed since these valves only function in a horizontal position. See factory for vertical down applications.

Check Rite horizontal assembly compared to conventional check valve assembly.

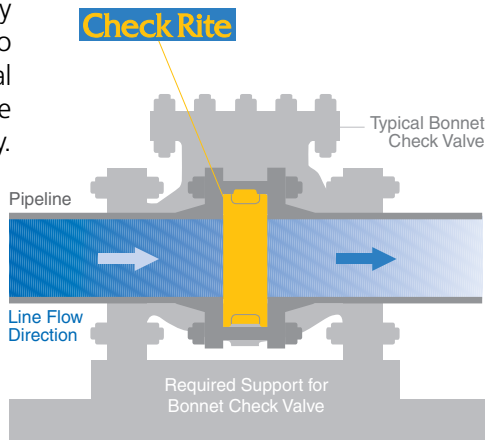

Check Rite vertical assembly compared to conventional check valve assembly.

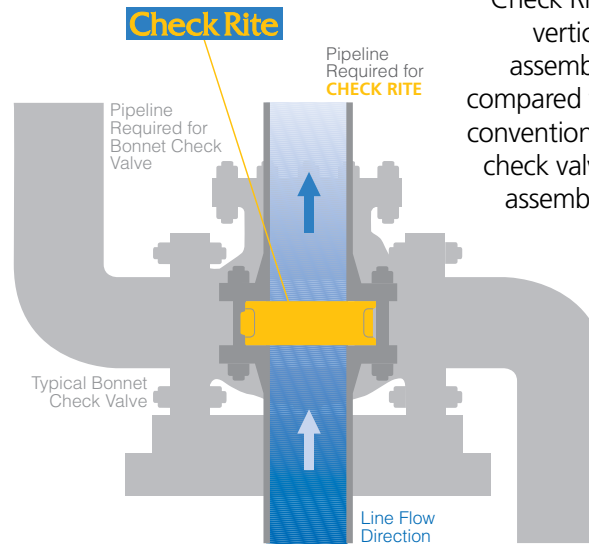

LIGHT WEIGHT & REDUCED SIZE Installation costs are greatly reduced by Check Rite's light weight and minimal space requirements. Their compact design minimizes the distance between faces and are easily installed between all flanges. Check Rite valves do not require added support to maintain pipeline integrity and need only 30% of the space of typical full size swing check valves.

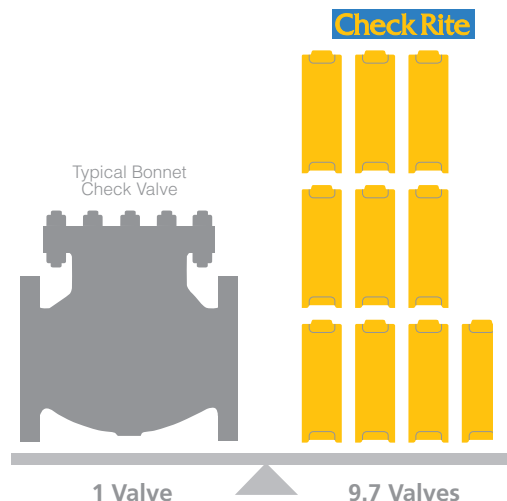

Ritepro has designed and manufactured an extensive range of accessories for special applications. Some commonly used accessories and a PVC body uniquely designed for a specific application are shown below. Check Rite valves can be fitted with any one or a combination of accessories, including safety caging.

EXTERNAL LEVER & SPRINGS (SA-01)

Provide additional external force to anticipate closure in applications where rapid media flow reversal requires the valve to close faster than standard.

Applications: Pump protection when pumping in parallel into a common header.



EXTERNAL LEVER & COMPRESSION SPRING (SA-40)

Provide additional force to anticipate valve closure, using an enclosed compression spring, in applications where rapid media flow reversal requires the valve to close faster than standard.

Applications: Pump protection when pumping in parallel into a common header, where spring force required is higher than a SA-01 or if an enclosed spring is preferred.

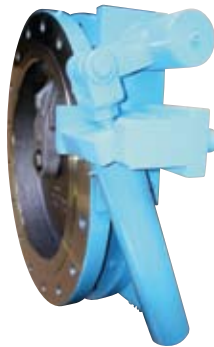

EXTERNAL LEVER & WEIGHT (SA-16)

Provide additional external mass to increase the cracking pressure (pressure required to open the disc) and increase the closing force of the moving disc.

Applications: Where increased cracking pressure is required. Waste Water service or where suspended solids are present in the process (the weight will insure inertia induced positive closure). Relief valve with adjustable cracking pressure.



EXTERNAL LEVER, SPRING & WEIGHT (SA-1)

These units use the combination of a weight and spring to add cracking pressure and closing force to the disc.

Applications: Where performing both functions of faster closure and solid handling are required, primarily in waste water.



DUAL WEIGHTS (SA-10)

Two opposing weights, one to adjust cracking pressure and one to counter balance the disc.

Applications: Insures valve is fully open on very low flows.



HYDRAULIC PNEUMATIC SPEED CONTROLS (H-100, SA-50)

Slow the opening of the valve to protect the disc assembly in the last few degrees of travel. These units offer adjustable speed control and are ideal in fluctuating flow applications. The H-100 uses the SA-01 spring. The SA-50 uses the SA-40 compression spring.



LIMIT SWITCH (SA-2)

Provides remote indication of valve position and a positive indication of flow. If two are installed the first shows the closed position, the second the fully opened valve. (A partially opened valve is subject to premature wear.)

Applications: Automated control systems.



PVC (PEZ SA-4AX)

PVC Body with passivated stainless steel or titanium internals and position indication lever. Eliminates internal body corrosion.

Applications: Used for Salt water, marine life support systems, desalination applications.



SELECTION PROCESS

- A Gather Process Information**
Line Fluid / Pressure / Temperature / Flow Rate / Location / Function
- B Gather Pipe Information**
Size / Material / Flange Rating / Schedule
- C Select Valve Size** – Based on:
• Full open valve at minimum flow
• or Pipe size
- D Select Design Standard**
• ASME: 125 / 150 / 300
• API 594: 150 / 300 / 400 / 600 / 900 / 1500 / 2500
• PN: 10 / 16 / 25 / 40
- E Verify Conditions**
• Valve full open at minimum flow
• Max velocity 15 f/sec for Liquid
• Max velocity Mach 0.33 for Gas
• Non-reciprocating service
• No accessories required
• Installed with a minimum of 5 pipe diameters upstream and 3 down stream from a disturbance
• Not installed on close coupled multiple pump header
- F Select Model**
If answer is **YES** to All conditions:
• Select Model 210 (ASME, DIN)
Models 201 - 205 (API 594)
• or if ULC FM* approved required select 212 (ASME), 312 (DIN)
If answer is **NO** to Any condition:
Select Model 260 (ASME, DIN)
Models 201 - 205 (API 594)
- G Select Pressure Class and Body, Seat & Spacers Materials**

ORDERING EXAMPLE

A 6" heavy duty, Class 150 wafer combination swing check valve, carbon steel body with stainless steel inserted seat, stainless steel spacers and an external spring accessory would be written as follows:

06 260 15 S M Z SA-01



SELECTION INFORMATION

| | | Description | Color |
|---|---|---|------------------|
| 1 Size | 01-60 | 1" - 60" ASME 25mm-1500mm DIN | |
| | 2 Model | 201 | API 594 #400/600 |
| 203 | | API 594 #900/1500 | Grey |
| 205 | | API 594 #150/300 | Grey |
| 210 | | Standard ASME / DIN | |
| 212 | | ULC FM Approved ASME * | Red |
| 312 | | ULC FM Approved DIN * | Red |
| 260 | | Heavy Duty ASME / DIN | |
| 3 Pressure Class | 211 | Flanged Body | |
| | 10 | PN 10 | |
| | 12 | ASME 125 lb | |
| | 15 | ASME 150 lb | |
| | 16 | PN 16 | |
| | 25 | PN 25 | |
| | 30 | ASME 300 lb | |
| | 40 | PN 40 | |
| 4 Body | – | Other | |
| | C | ASTM A 126 CLB | Black |
| | D | ASTM A 395 | Grey |
| | S | ASTM A 216 WCB | Yellow |
| | X | ASTM A 351 CF8M | None |
| | T | Titanium | None |
| 5 Seat | – | Other ** | |
| | B | BUNA -N | |
| | E | EPDM | |
| | M | A240 - 304 (Inserted or Integral) *** | |
| | T | PTFE | |
| 6 Spacers | V | FKM | |
| | T | PTFE (Standard on 1" -12" Cast Iron Bodies) | |
| | Z | A479 - 316 | |
| 7 Special Application Accessories | – | Other ** | |
| | SA-01 | External Spring | |
| | SA-1 | External Spring & Weight | |
| | SA-2 | Limit Switch | |
| | SA-3 | Backflush Lever and External Spring | |
| | SA-4 | External Position Indicator | |
| | SA-4A | Backflush Lever | |
| | SA-7 | Emergency Shut-off, Fusible Link | |
| | SA-10 | Dual Balanced Weights | |
| | SA-16 | External Weight | |
| | SA-40 | External Compression Spring | |
| SA-40A | External Compression Spring and Weight | | |
| H-100 | External Spring, Weight, Hydraulic Damper | | |
| SA-50 | External Compression Spring, Weight, & Hydraulic Damper | | |
| – | Other | | |

* ULC Approved under NFPA No. 11,13,14,15,20,22,24. FM Approved.

** Available in most exotic materials, please consult factory.

*** Inserted pressed-in interference seat at a minimum of 304 SS for carbon steel and ductile iron bodies, or seat is intergral to body.

Note: Spacers are located on both sides of the disc hinge, ensuring a uniform seal.

Note: The standard Check Rite is a wafer body style. Flanged Ends, RTJ style and other connections are available, please consult factory.

Models 210 (ANSI), 205 (API 594), Class 125/150

| Nominal Pipe Size | | A 210 | | A 205 | | B 210/205 | | C | | D | | Weight 210 SS | | Weight 205 SS | | | |
|-------------------|------|----------|-------|----------|-------|--------------|--------|--------|--------|--------|-------|------------------|--------|------------------|--------|------|------|
| Inch | mm | Inch | mm | Inch | mm | Inch | mm | Inch | mm | Inch | mm | lbs | kg | lbs | kg | | |
| 1 | 25 | 2 | 50.8 | | | 2 5/8 | 66.7 | 3.4 | 86.3 | | | | | 1.9 | 0.85 | | |
| 1 1/2 | 38 | 2 3/4 | 69.8 | | | 3 3/8 | 85.7 | 4 1/8 | 104.7 | | | 3.8 | 1.8 | | | | |
| 2 | 50 | 1 3/4 | 44.5 | 2 1/8* | 44.5 | 2 3/8 | 60.3 | 4 1/8 | 104.8 | 4 1/4 | 107.9 | 1 3/16 | 30.1 | 4.2 | 1.9 | 6.0 | 2.7 |
| 2 1/2 | 65 | 1 7/8 | 47.6 | 2 3/8* | 47.6 | 2 5/8 | 66.7 | 4 7/8 | 123.8 | 4 1/2 | 114.3 | 1 3/8 | 34.9 | 6.1 | 2.8 | 9.0 | 4.1 |
| 3 | 80 | 2 | 50.8 | 2 5/8* | 50.8 | 2 7/8 | 73.0 | 5 3/8 | 136.5 | 5 | 127.0 | 1 5/8 | 41.2 | 8.4 | 3.8 | 13.0 | 5.9 |
| 4 | 100 | 2 1/4 | 57.2 | 2 7/8 | 57.2 | 2 7/8 | 73.0 | 6 7/8 | 174.6 | 5 3/4 | 146.0 | 2 3/4 | 69.8 | 13.5 | 6.2 | 19.3 | 8.75 |
| 5 | 125 | 2 1/2 | 63.5 | 3 1/4 | 63.5 | 7 3/4 | 196.9 | 6 1/2 | 165.1 | 3 5/8 | 92.0 | 18.1 | 8.2 | 23.0 | 10.4 | | |
| 6 | 150 | 2 3/4 | 69.9 | 3 7/8 | 69.9 | 8 3/4 | 222.3 | 7 1/4 | 184.5 | 4 1/2 | 114.3 | 22.5 | 10.2 | 34.0 | 15.4 | | |
| 8 | 200 | 2 7/8 | 73.0 | 5 | 127.0 | 11 | 279.4 | 8 1/4 | 209.5 | 5 3/4 | 146.0 | 34.5 | 15.7 | 65.0 | 29.5 | | |
| 10 | 250 | 3 1/8 | 79.4 | 5 3/4 | 146.0 | 13 3/8 | 339.7 | 9 5/8 | 244.4 | 7 1/2 | 190.5 | 50.9 | 23.1 | 88.1 | 40 | | |
| 12 | 300 | 3 3/8 | 85.7 | 7 1/8 | 181.0 | 16 1/8 | 409.6 | 10 3/4 | 273.0 | 8 3/4 | 222.2 | 83.7 | 38.0 | 154.2 | 70 | | |
| 14 | 350 | 4 1/4 | 108.0 | 7 1/4 | 184.0 | 17 5/8 | 447.7 | 13 | 330.2 | 7 1/4 | 184.1 | 115.0 | 53.0 | 200 | 90.8 | | |
| 16 | 400 | 4 1/4 | 108.0 | 7 1/2 | 191.0 | 20 1/8 | 511.2 | 14 1/2 | 368.3 | 8 1/4 | 209.5 | 130.0 | 59.0 | 230 | 104.4 | | |
| 18 | 450 | 4 1/4 | 108.0 | 8 | 203.0 | 21 1/2 | 546.1 | 15 1/4 | 387.3 | 10 1/2 | 266.7 | 170.0 | 77.2 | 320 | 145.3 | | |
| 20 | 500 | 5 1/2 | 139.7 | 8 5/8 | 219.0 | 23 3/4 | 603.3 | 18 3/4 | 476.2 | 11 | 279.4 | 230.0 | 104.4 | 360 | 163.4 | | |
| 24 | 600 | 6 | 152.4 | 8 3/4 | 222.0 | 28 3/16 | 716.0 | 20 1/2 | 520.7 | 15 | 381.0 | 385.0 | 175.0 | 560 | 254.2 | | |
| 28 | 700 | 6 1/2 | 165.1 | | | 32 5/8 | 828.7 | 26 | 660.4 | 17 3/4 | 450.8 | 580.0 | 263.3 | | | | |
| 30 | 750 | 9 | 228.6 | 12 | 305.0 | 34 5/8 | 879.5 | 27 1/2 | 698.5 | 16 1/4 | 412.7 | 965.0 | 438.1 | 1300 | 590.2 | | |
| 32 | 800 | 9 | 228.6 | | | 36 13/16 | 936.8 | 29 | 736.6 | 16 3/4 | 425.4 | 1235.0 | 560.7 | | | | |
| 36 | 900 | 11 1/2 | 292.1 | 14 1/2 | 368.0 | 41 1/8 | 1044.6 | 30 | 762.0 | 18 1/4 | 463.5 | 1525.0 | 692.4 | 2000 | 908.0 | | |
| 40 | 1000 | 11 1/2 | 292.1 | | | 45 5/8 | 1158.9 | 35 1/4 | 895.3 | 21 1/2 | 546.1 | 2200.0 | 998.8 | | | | |
| 42 | 1050 | 12 | 304.8 | 17 | 432.0 | 48 | 1219.2 | 33 1/4 | 844.5 | 28 | 711.2 | 2235.0 | 1014.7 | 3200 | 1452.8 | | |
| 48 | 1200 | 14 | 355.6 | 20 5/8 | 523.9 | 54 1/2 | 1384.3 | 38 1/4 | 971.5 | 24 1/2 | 622.3 | 3250.0 | 1475.5 | 3910 | 1775 | | |
| 54 | 1350 | 23 | 584.2 | | | 61 | 1549.4 | 43 | 1092.2 | 19 3/8 | 492.1 | 5500.0 | 2497.0 | | | | |
| 60 | 1500 | 23 | 584.2 | | | 67 3/8 | 1711.3 | 38 1/4 | 971.5 | 33 | 838.2 | 7000.0 | 3178.0 | | | | |

* For Cast Iron

Models 210 (ANSI), 205 (API 594), Class 300

| Nominal Pipe Size | | A 210 | | A 205 | | B 210/205 | | C | | D | | Weight 210 | | Weight 205 | |
|-------------------|-----|----------|-------|----------|-------|--------------|-------|--------|-------|---------|-------|---------------|-------|---------------|-------|
| Inch | mm | Inch | mm | Inch | mm | Inch | mm | Inch | mm | Inch | mm | lbs | kg | lbs | kg |
| 1 | 25 | 2 | 50.8 | | | 2 7/8 | 73.0 | 3 2/5 | 86.4 | | | 1.9 | 0.85 | | |
| 1 1/2 | 38 | 2 3/4 | 69.8 | | | 3 3/4 | 95.2 | 4 1/8 | 104.8 | | | 4.4 | 2.0 | | |
| 2 | 50 | 1 3/4 | 44.5 | 2 3/8 | 60.3 | 4 3/8 | 111.1 | 4 1/4 | 108.0 | 1 3/16 | 30.0 | 4.0 | 1.8 | 8.4 | 3.8 |
| 2 1/2 | 65 | 1 7/8 | 47.6 | 2 5/8 | 66.7 | 5 1/8 | 130.2 | 4 1/2 | 114.0 | 1 1/2 | 38.0 | 5.9 | 2.7 | 13.2 | 6.0 |
| 3 | 80 | 2 | 50.8 | 2 7/8 | 73.0 | 5 7/8 | 149.2 | 5 | 127.0 | 1 11/16 | 43.0 | 7.9 | 3.6 | 15.4 | 7.0 |
| 4 | 100 | 2 1/4 | 57.2 | 2 7/8 | 73.0 | 7 1/8 | 181.0 | 5 3/4 | 146.0 | 2 7/16 | 62.0 | 11.9 | 5.4 | 22.5 | 10.2 |
| 5 | 125 | 2 1/2 | 63.5 | 3 1/4 | 82.5 | 8 1/2 | 215.9 | 6 1/2 | 165.0 | 3 3/8 | 86.0 | 18.9 | 8.6 | 27.5 | 12.5 |
| 6 | 150 | 2 3/4 | 69.9 | 3 7/8 | 98.4 | 9 7/8 | 250.8 | 7 1/4 | 184.0 | 4 1/4 | 108.0 | 26.9 | 12.2 | 43.0 | 19.5 |
| 8 | 200 | 2 7/8 | 73.0 | 5 | 127.0 | 12 1/8 | 308.0 | 8 1/4 | 210.0 | 5 3/8 | 136.0 | 41.9 | 19.0 | 76.0 | 34.5 |
| 10 | 250 | 3 1/8 | 79.4 | 5 3/4 | 146.0 | 14 1/4 | 362.0 | 9 5/8 | 244.0 | 7 | 178.0 | 61.7 | 28.0 | 109.0 | 49.5 |
| 12 | 300 | 3 3/8 | 85.7 | 7 1/8 | 181.0 | 16 5/8 | 422.3 | 10 3/4 | 273.0 | 8 1/8 | 206.0 | 94.7 | 43.0 | 198.2 | 90.0 |
| 14 | 350 | 4 1/4 | 108.0 | 8 3/4 | 222.0 | 19 1/8 | 486.0 | 13 | 330.0 | 7 1/4 | 184.0 | 286.3 | 130.0 | 286.3 | 130.0 |
| 16 | 400 | 4 1/4 | 108.0 | 9 1/8 | 232.0 | 21 1/4 | 540.0 | 14 1/2 | 368.0 | 8 1/4 | 210.0 | 352.4 | 160.0 | 352.4 | 160.0 |
| 18 | 450 | 10 3/8 | 263.5 | 10 3/8 | 264.0 | 23 1/2 | 597.0 | 15 1/4 | 387.0 | 10 1/2 | 267.0 | 440.5 | 200.0 | 440.5 | 200.0 |
| 20 | 500 | 11 1/2 | 292.1 | 11 1/2 | 292.0 | 25 3/4 | 654.0 | 18 3/4 | 476.0 | 11 | 280.0 | 572.7 | 260.0 | 572.7 | 260.0 |
| 24 | 600 | 12 1/2 | 317.5 | 12 1/2 | 318.0 | 30 1/2 | 774.0 | 20 1/2 | 520.0 | 15 | 381.0 | 925.1 | 420.0 | 925.1 | 420.0 |

Model 201 (API 594), Class 600

| Nominal Pipe Size | | A | | B 400lbs | | B 600lbs | | C | | D | | Weight | |
|-------------------|-----|-------|-------|-------------|-------|-------------|-------|--------|-----|-------|-----|--------|-----|
| Inch | mm | Inch | mm | Inch | mm | Inch | mm | Inch | mm | Inch | mm | lbs | kg |
| 2 | 50 | 2 3/8 | 60.3 | 4 3/8 | 111.1 | 4 3/8 | 111.1 | 4 5/8 | 117 | 1/2 | 13 | 7 | 3 |
| 2 1/2 | 65 | 2 5/8 | 66.7 | 5 1/8 | 130.2 | 5 1/8 | 130.2 | 5 1/8 | 130 | 5/8 | 16 | 10 | 4.5 |
| 3 | 80 | 2 7/8 | 73 | 5 7/8 | 149.2 | 5 7/8 | 149.2 | 6 | 152 | 3/4 | 19 | 14.5 | 6.6 |
| 4 | 100 | 3 1/8 | 79.4 | 7 | 177.8 | 7 5/8 | 193.7 | 6 3/4 | 171 | 1 1/2 | 38 | 24 | 11 |
| 6 | 150 | 5 3/8 | 136.5 | 9 3/4 | 247.6 | 10 1/2 | 266.7 | 9 1/2 | 241 | 2 1/8 | 54 | 54 | 25 |
| 8 | 200 | 6 1/2 | 165.1 | 12 | 304.8 | 12 5/8 | 320.7 | 10 3/4 | 273 | 2 3/4 | 70 | 96 | 44 |
| 10 | 250 | 8 3/8 | 212.7 | 14 1/8 | 358.8 | 15 3/4 | 400 | 12 | 305 | 3 | 76 | 171 | 78 |
| 12 | 300 | 9 | 228.6 | 16 1/2 | 419.1 | 18 | 457.2 | 14 3/4 | 375 | 4 1/8 | 105 | 250 | 114 |



Ritepro Corporation
A Subsidiary of Bray International, Inc.

12200 Albert Hudon, Montréal, Québec, Canada H1G 3K7
Tél 514.324.8900 Fax 514.324.9525 ritepro.com

© 2008 Ritepro Corporation. All rights reserved. Catalog 31 02/08